



RAMSA

SPEAKER SYSTEM

WS-A80

Operating Instructions

Panasonic

Before operating this set, please read these instructions completely.

GENERAL

- This speaker system is a 2-way bass-reflex type speaker system incorporating a 20cm (8") woofer and a Twin Bessel horn tweeter having constant directivity.
 - It is designed to accept a continuous program input of 160W. This speaker system is ideally suited as a main speaker. The compact design assures full portability and easy installation.
 - The tweeter and woofer are each equipped with an auto-reset type thermal protector to protect them against excessive input levels.
 - The Twin Bessel horn is designed to minimize the reflection of sound from the open end of the horn and to provide a directivity of 60° (horizontal) by 60° (vertical). This improvement in the constant directivity is effective in eliminating feedback.
 - The enclosure is a resin molded type and can be set in any desired position.
- The recessed handles and close-contour design prevent impact damage in transit, while the rigid, weather and temperature resistant cabinet insures long-term reliability.
- The enclosure features a stacking structure to enable secure stacking of speakers.
- The front of the enclosure is covered with a punched metal grille to protect the woofer and tweeter.
 - The speaker input jacks (phone plugs) can be replaced with XLR-type connectors.

CAUTIONS FOR INSTALLATION

- When installing the speaker on a wall or ceiling, it should be secured firmly using rigid anchor bolts to prevent it from coming off.
- If the speaker is operated at high output levels, the floor, wall or ceiling may vibrate, which will impair the sound quality. Special care should be taken to prevent resonance and vibrations caused by the mounting angles.

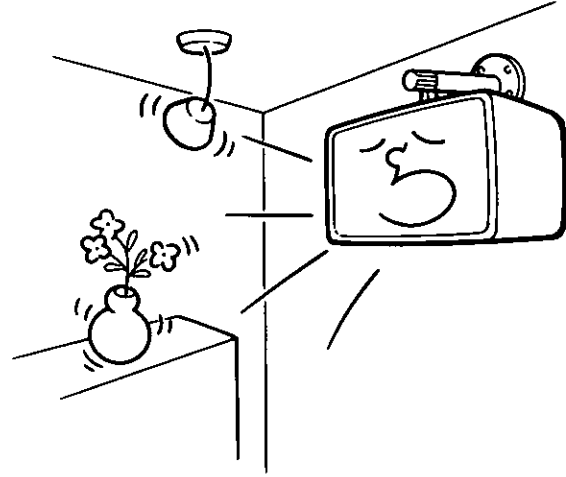
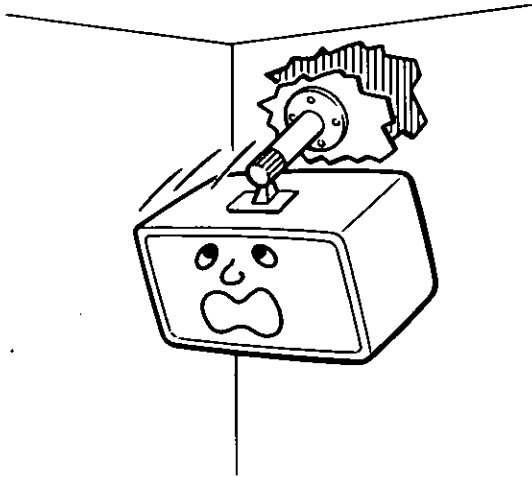

- The speaker can be mounted vertically or horizontally. Select a suitable mounting position according to the place of installation. Please note that the direction of the RAMSA logo cannot be changed.

CAUTIONS FOR CONNECTION

- Before connecting the speaker, be sure to turn off the amplifier power switch.
- The input impedance of this speaker is 8 ohms. Check to make sure that the amplifier to be connected is designed to be used with speakers with a 4 to 8 ohms impedance rating.
- The connecting cable used for the speaker and amplifier should be as large as possible in diameter to minimize the DC resistance.
- When two or more speakers are to be used in the same room, be sure to match the polarity. The plus \oplus and minus \ominus push-terminal of each speaker are marked red and black, respectively.
- Up to two speakers may be connected in parallel.

CONNECTION OF SPEAKER CABLES

There are two types of speaker input terminals which should be selected according to applications. (The three terminals are internally connected in parallel.)

■ Use of push-terminals

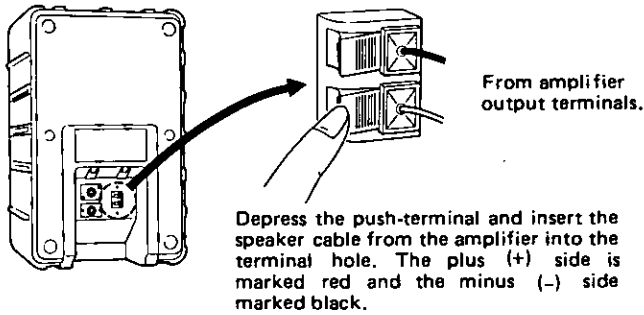

■ Use of phone jacks

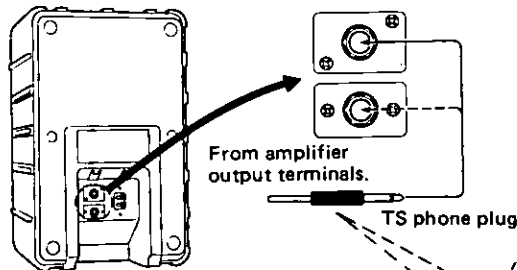

The speaker uses a TS phone plugs as an input terminal. When connecting, make sure that the polarity of the TS phone plug matches the polarity of the amplifier output terminals (speaker terminal) as shown in the illustration.

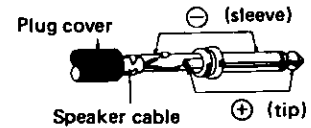

NOTES:

- The cable which fits in the hole of the push-terminal, should have a diameter not larger than 7/64" (2.6 mm). To ensure proper fit to the terminal, a cable diameter of less than 5/64" (2 mm) is recommended.
- The sheath of the speaker cable should not be inserted into the terminal hole.
- When the speaker cable is of a stranded type, the core conductor should be twisted before inserting it into the terminal hole.

NOTES:

- Connect the speaker cable to a tip-sleeve (TS) phone plug, then connect it to either jack.
- The other jack is then used when installing an additional speaker in parallel.

■ Installation of additional speakers

Connect the speakers in parallel as shown below.

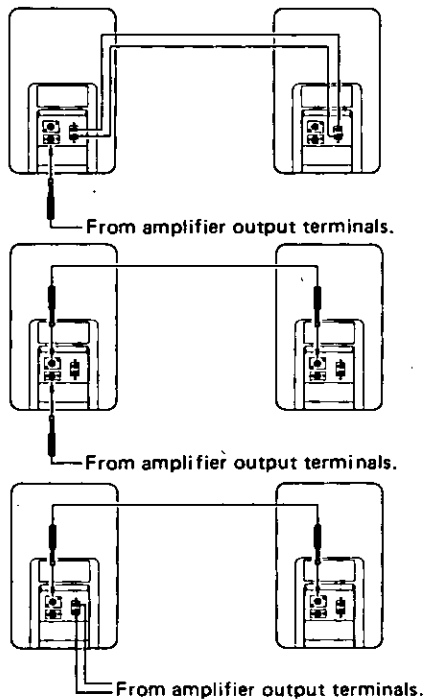

When two speakers are connected in parallel, the combined impedance becomes 4 ohms. In this case, the speakers should be connected to an amplifier which is designed to drive a load impedance of 4 ohms or less.

NOTES:

- When three or more speakers are connected in parallel, the combined impedance becomes 3 ohms or less which requires a special type of amplifier. Therefore, do not use more than two speakers for parallel connection.
- If the combined impedance of the speakers is lower than the specified impedance on the amplifier to be used, the sound from the speakers may be distorted or the amplifier may be damaged.
- When two speakers are used in parallel, make sure that the polarity of these speakers are the same.

USE OF XLR-TYPE CONNECTOR

This speaker may be fitted with an XLR-type connector which is often used for professional applications.

- Remove the phone jack mounting plate and pull it forward. Disconnect the wiring.

Phone jack mounting plate

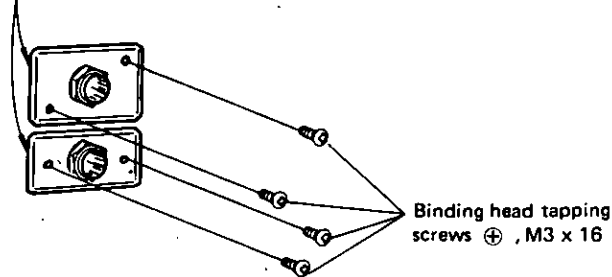

Use these screws for mounting the XLR-type connector.

- Solder the leads that were disconnected in step ① as shown below (⊕ on pin 2, ⊖ on pin 3), mount a female-type XLR on the top and a male-type XLR on the bottom.

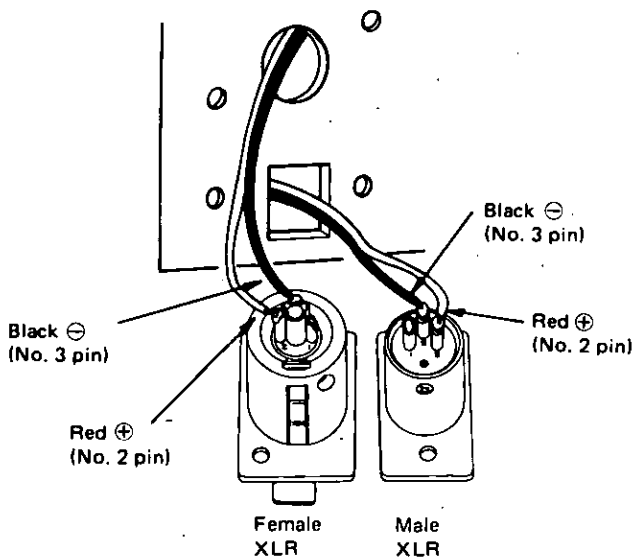

- Secure the XLR-type connectors with the screws which were removed in step ①, as illustrated.

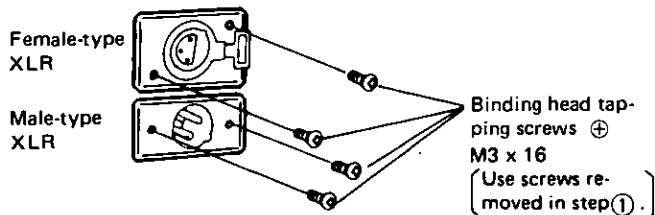

For connection, use XLR-type plug.

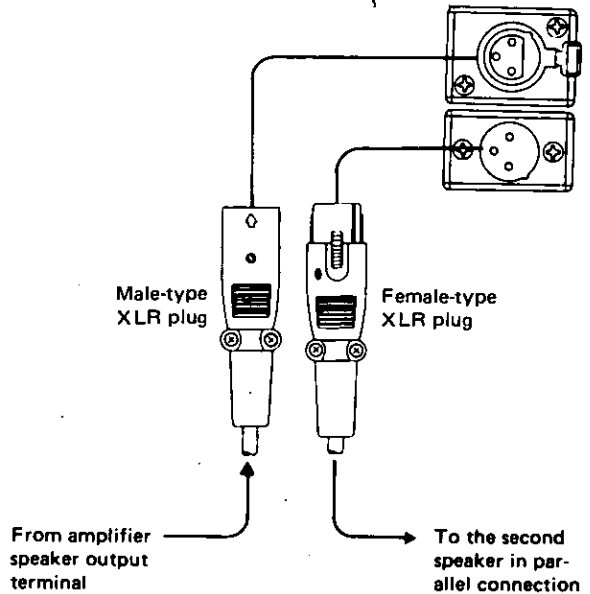

Disassembly diagram of typical Female XLR plug

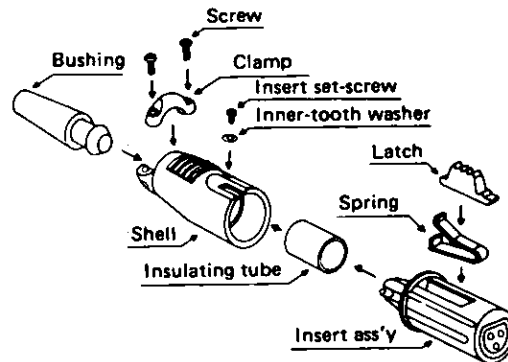

Disassembly diagram of typical Male XLR plug

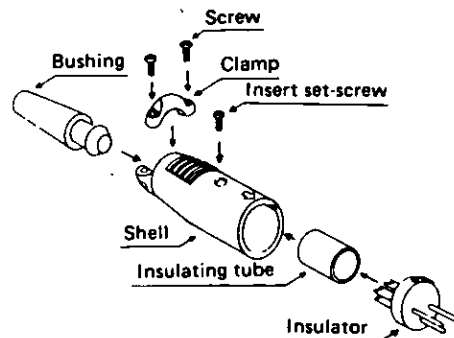

NOTE:

- When using XLR-type connectors, observe the polarity as shown below.

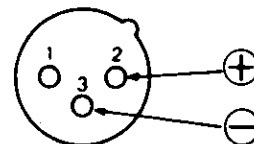

POWER HANDLING CAPACITY

The maximum input to the speaker is 160W (continuous program). Care should be taken not to apply excessive input or abnormal signals to the speaker.

- When using a high output amplifier, be careful of setting the amplifier volume control to avoid excessive input.
- Even when an amplifier with maximum output of less than 160W is used, if the input signal is too large or the volume control is set to too high a position, the amplifier output may be distorted, possibly damaging the speakers. Special care should be directed to the amplifier input and output levels.
- When bass and treble levels are increased by the tone control, loudness control or equalizer of the amplifier, a large power is applied to the speaker. So the volume control should be set with care.

- When the following special signals are applied to the speaker system, a large current flows into the speaker which may result in damage to the voice coil even when such signals are below the maximum input level. In this case, be sure to turn down the volume control of the amplifier.

1. Inter-station noise in FM broadcast.
2. High frequency noise during fast-forward or rewind operation of a tape deck.
3. Feedback from microphones or electronic musical instruments.
4. Shock noise caused when the power switch of the amplifier or condenser microphone is turned on or off, or at connection and disconnection of the input/output terminals.
5. Continuous high or low frequency signal developed from an oscillator or electronic musical instrument (music synthesizer).

PROTECTION CIRCUIT

- The speaker has a protection circuit. When an excessive input is applied to the speaker, the protection circuit is activated to attenuate the input level.
- When the protection circuit is activated, the sound pressure level of the woofer is sharply reduced and tweeter is cut off. In this case, turn down the volume control of the amplifier and wait until the protection circuit is automatically reset (about 2 to 20 seconds).
- If, during operation of the protection circuit, the amplifier volume level is not reduced or it is increased after the sound has become low, the protection circuit will operate repeatedly, which may damage the speaker.

BLOCK DIAGRAM

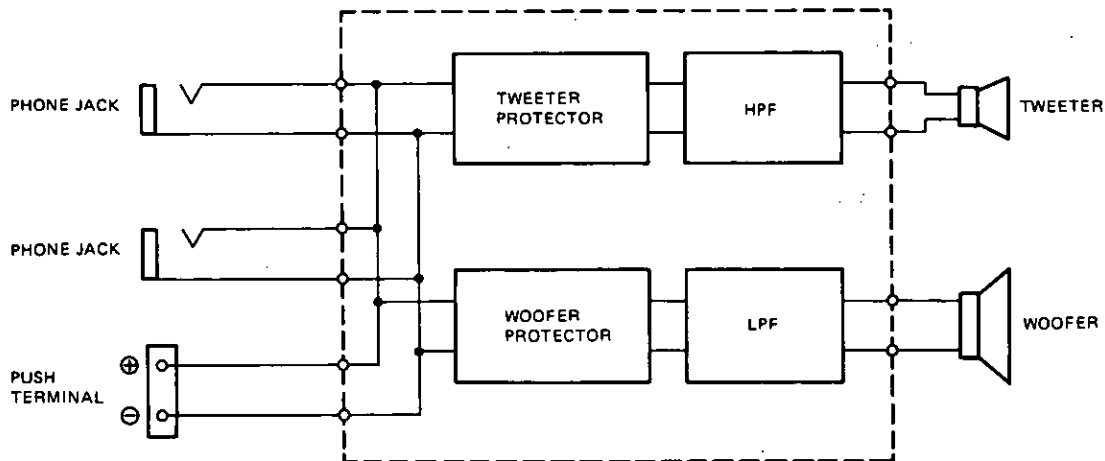

INSTALLATION EXAMPLES

■ On a speaker stand

The speaker can be mounted on a speaker stand, allowing extra flexibility in selecting a location.

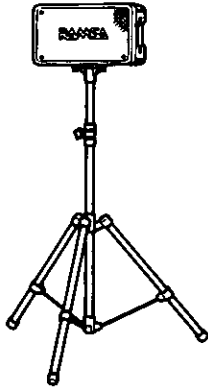

■ As a foldback speaker

A stand such as shown below may be inserted into the holes on the rear of the cabinet so that it can lean back and be used for Foldback.

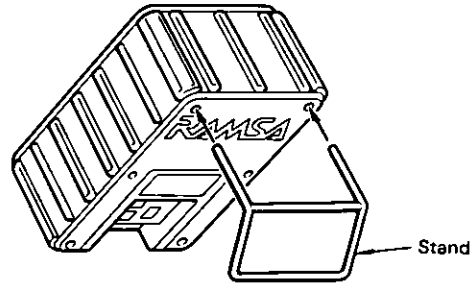

Place the speaker in the upright position.

■ Wall or ceiling mount

The speaker can be mounted on a wall or hung from the ceiling using a suitable bracket.

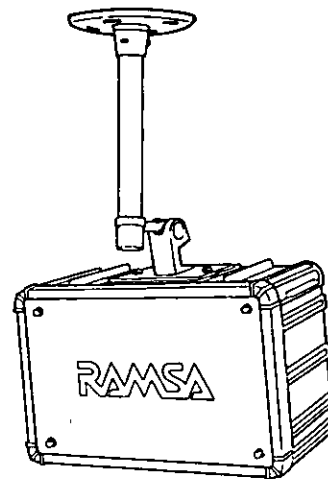
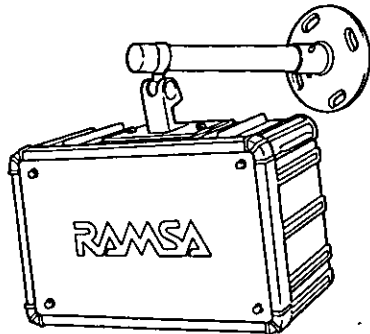

Note:

These stands and brackets are not supplied.

CAUTION

- For safest mounting and to avoid damage to the mounting threads, use the mounting screws provided and hand-tighten only.
- If selecting mounting screws from an outside source, please refer to effective depth of screw, described in the "Appearance" section of this manual.

SPECIFICATIONS AND ACCESSORIES

■ Specifications

Type:	2-way, bass reflex type
Input impedance:	8 ohms
Power handling capacity:	160W (continuous program input) 80W (RMS)*
Sound pressure level:	92 dB (1W, 1m)
Frequency response:	65 to 20,000 Hz
Crossover frequency:	2,500 Hz
Speaker:	Woofer: 20cm (8") cone speaker Tweeter: Twin Bessel horn speaker
Dispersion:	60° (horizontal) x 60° (vertical)
Dimensions:	17-1/16" (W) x 11-1/8" (H) x 9-5/16" (D) (434mm) (282mm) (237mm)
Weight:	Approx. 16.5 lbs (7.5 kg)
Finish:	Enclosure: Resin molded, black Front panel: Punched grille, black

* True effective power measured by the test method prescribed by AMERICAN NATIONAL STANDARD EIA (Electronic Industries Association) RS-426-A (1980).

In this test, a noise signal with an increased high frequency power component was used as a test signal to match the latest program sources.

■ Accessories

Operating Instructions	1
Thumb screw (M8 x 25)	2

TYPICAL RESPONSE

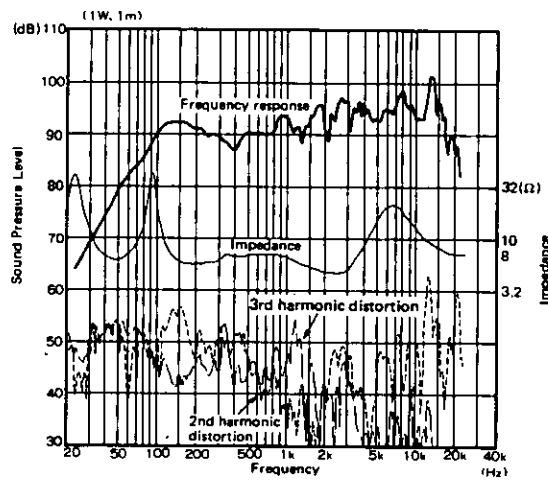

DIRECTIVITY

< HORIZONTAL >

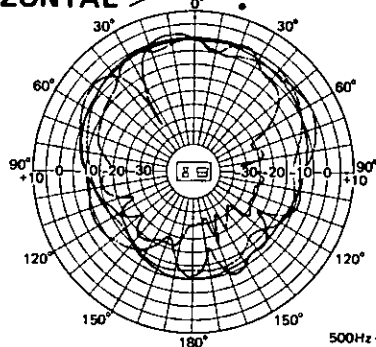

< VERTICAL >

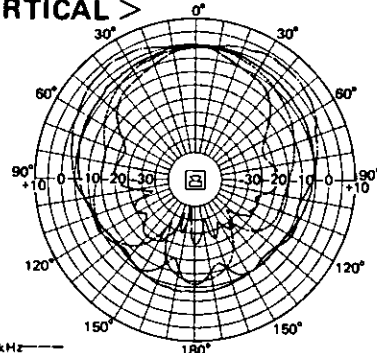

APPEARANCE

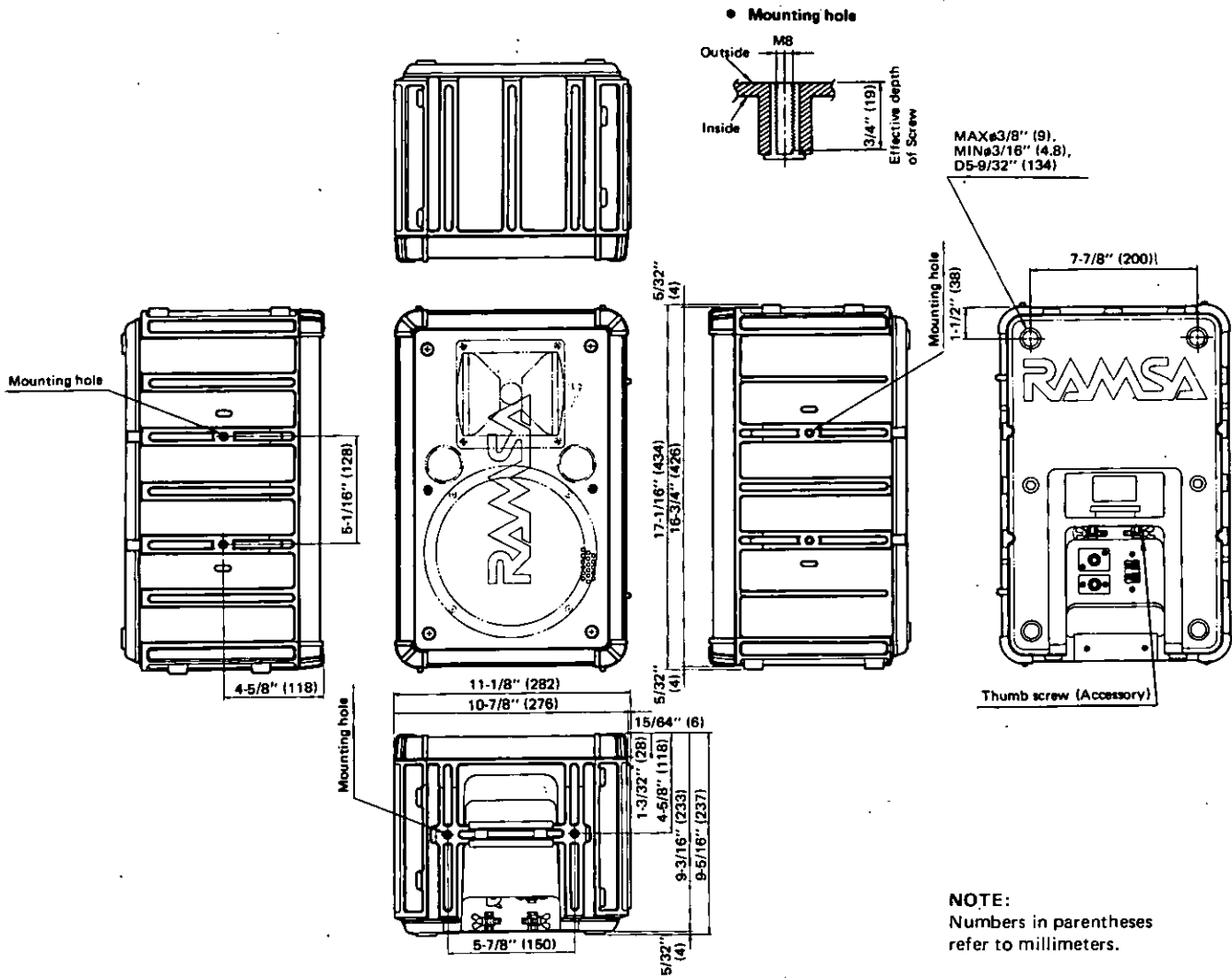

Panasonic Industrial Company

AUDIO-VIDEO SYSTEMS GROUP
PROFESSIONAL AUDIO SYSTEMS
One Panasonic Way, Secaucus, NJ 07094
(201) 348-7470

INDUSTRIAL AUDIO DEPARTMENT
MATSUSHITA ELECTRIC OF CANADA LIMITED
5770 Ambler Drive
Mississauga, Ontario, L4W 2T3 (416) 624-5010